

Replacing the HiTAC® water filter

This guide shows how to replace the HiTAC® water filter for PRO3-VAQ and PRO3-VAQ E tanks.
The replacement for COMBI and COMBI E tanks is similar and is also explained.

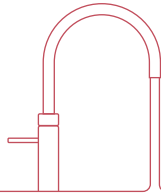

Introduction

This guide contains two sections. You will have to determine the type of tank you have in order to choose the correct section of this guide. There are two ways to do that:

1 By checking the type of Quooker tap you have.

In case you have a Flex tap, a Fusion tap or a Nordic boiling-water tap, you have an E tank.

Use the first section of this guide.

In case you have a Basic, Classic, Design or Modern boiling-water tap, you have a regular tank.

Use the second section of this guide.

Go to www.quooker.co.uk/collection if you are not sure.

2 By checking the serial number on your tank.

In case the serial number starts with 3 letters (VCF or CCW for example), you have an E tank.

Use the first section of this guide.

In case the serial number starts with 2 letters (VC or CC for example), you have a regular tank,

use the second section of this guide.

We recommend to keep paper towels within reach since some water will be left behind in the hoses and tank.

Section 1: Replacing the HiTAC® water filter of the E tank

1. Switch off the tank with the Q-shaped button on top. Do not unplug it or switch off the power yet.
2. Dispense boiling and cold water together. Leave it to run until the water is completely cold and the hose between the tap and the tank has cooled down.
3. Close the stop valve (small grey knob) on the inlet combination.
4. Open the boiling-water tap. If it is depressurised, no water will flow out of it.
5. Unplug the tank and disconnect the LED cable from the back of the tank.
6. Disconnect the flexible hose between the tap and the tank by turning the nut anti-clockwise (use spanners 10 and 14).
7. In case of a PRO3-VAQ E tank, disconnect the hose from the inlet combination by turning the nut anti-clockwise (use spanner 24). In case of a COMBI E tank, disconnect the two hoses from the mixing valve (use spanner 17 and 24). Remove the tank from the kitchen cabinet.

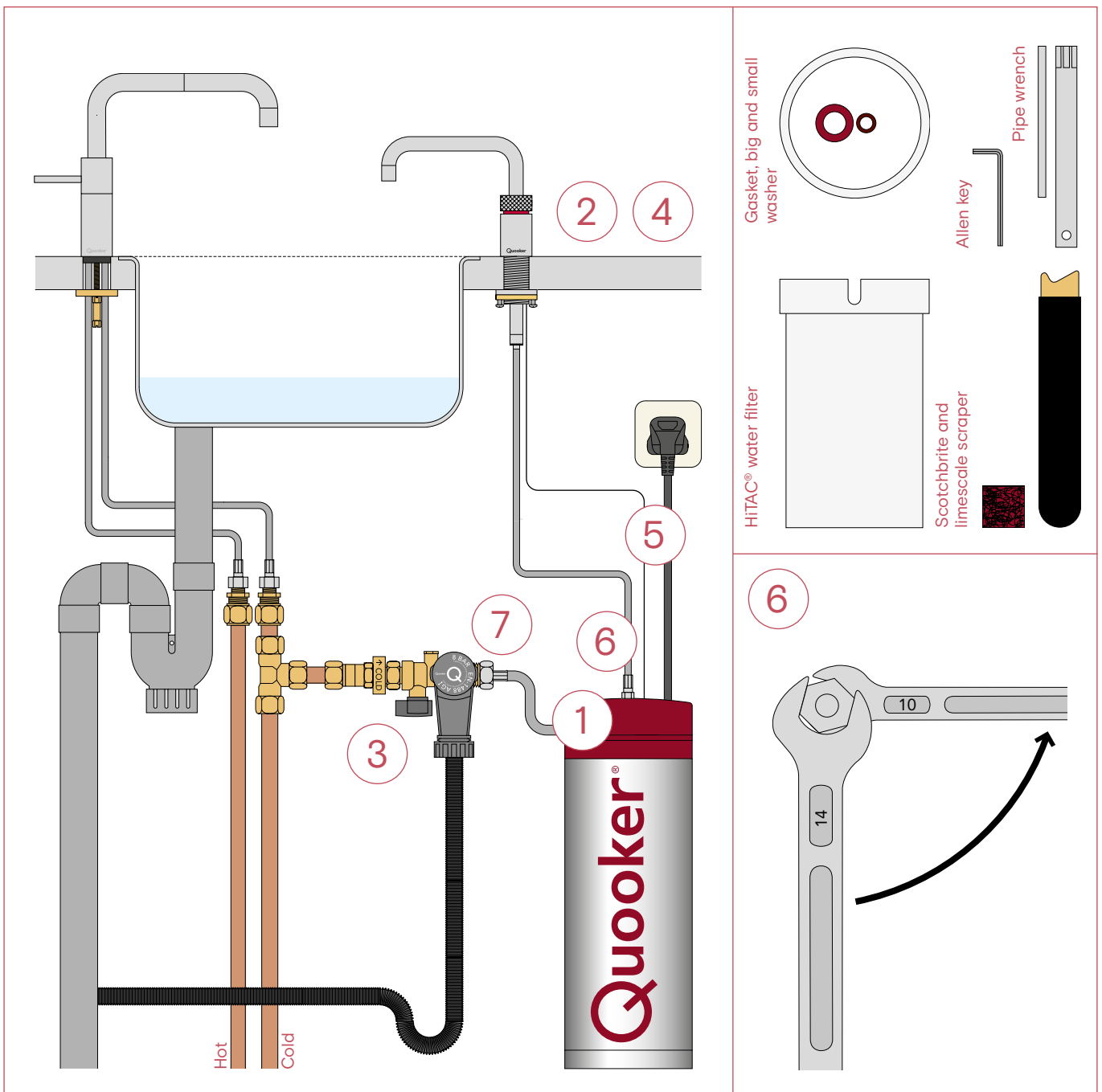

8. Unscrew the cap screws with the supplied allen key and lift the cover. Push the hose connector through the hole in the cover and gently disconnect the three wire plugs.
9. Remove the insulation.
10. Use the pipe wrench to unscrew the eight nuts anti-clockwise and remove the internals.
Please note: There is still water left in the tank.
11. Remove the filter by pulling the metal clips apart. Empty the tank and discard any loose scale.
Use the supplied Scotchbrite and water to lightly remove the bulk of the scale from the tank and internals.

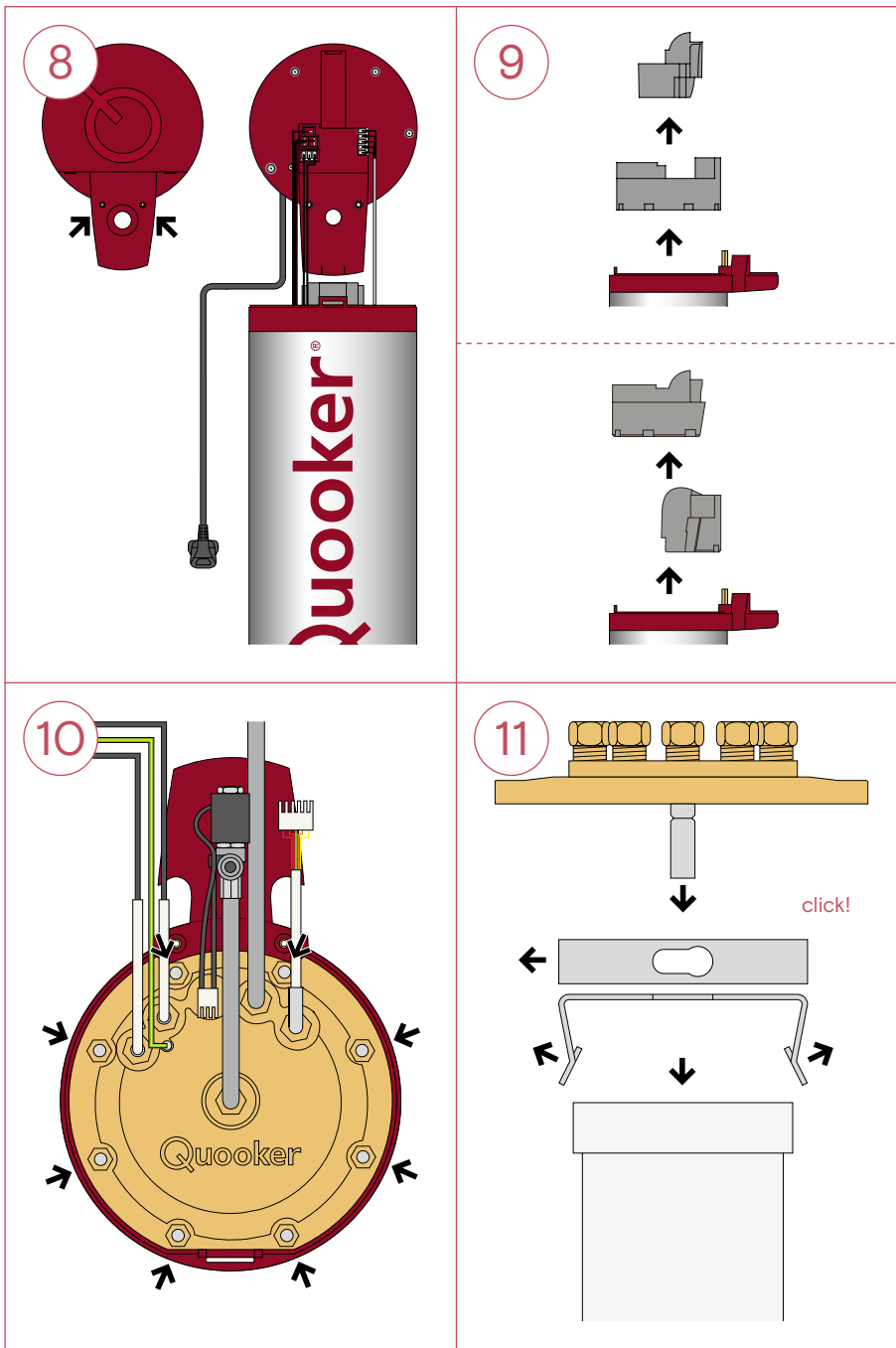

Please note

Do not use any descaling agents or abrasive pads when removing scale from the tank.

12. Type A internals: remove the transparent hose from the metal nozzle at the top. Clean scale from the inside of the nozzle, use the allen key to remove any blockages. Push the hose back in the nozzle all the way.
 - Type B internals: move to step 13.
13. Remove the white gasket (G). Ensure that the surface of the plate is dry and clean and put the new gasket in place.
 - Fit the new filter.
14. Ensure that the rim of the tank is clean by using the scraper and Scotchbrite.
15. Dry the entire rim including the seams and bolts with paper towel, while holding the tank upside down at an angle.

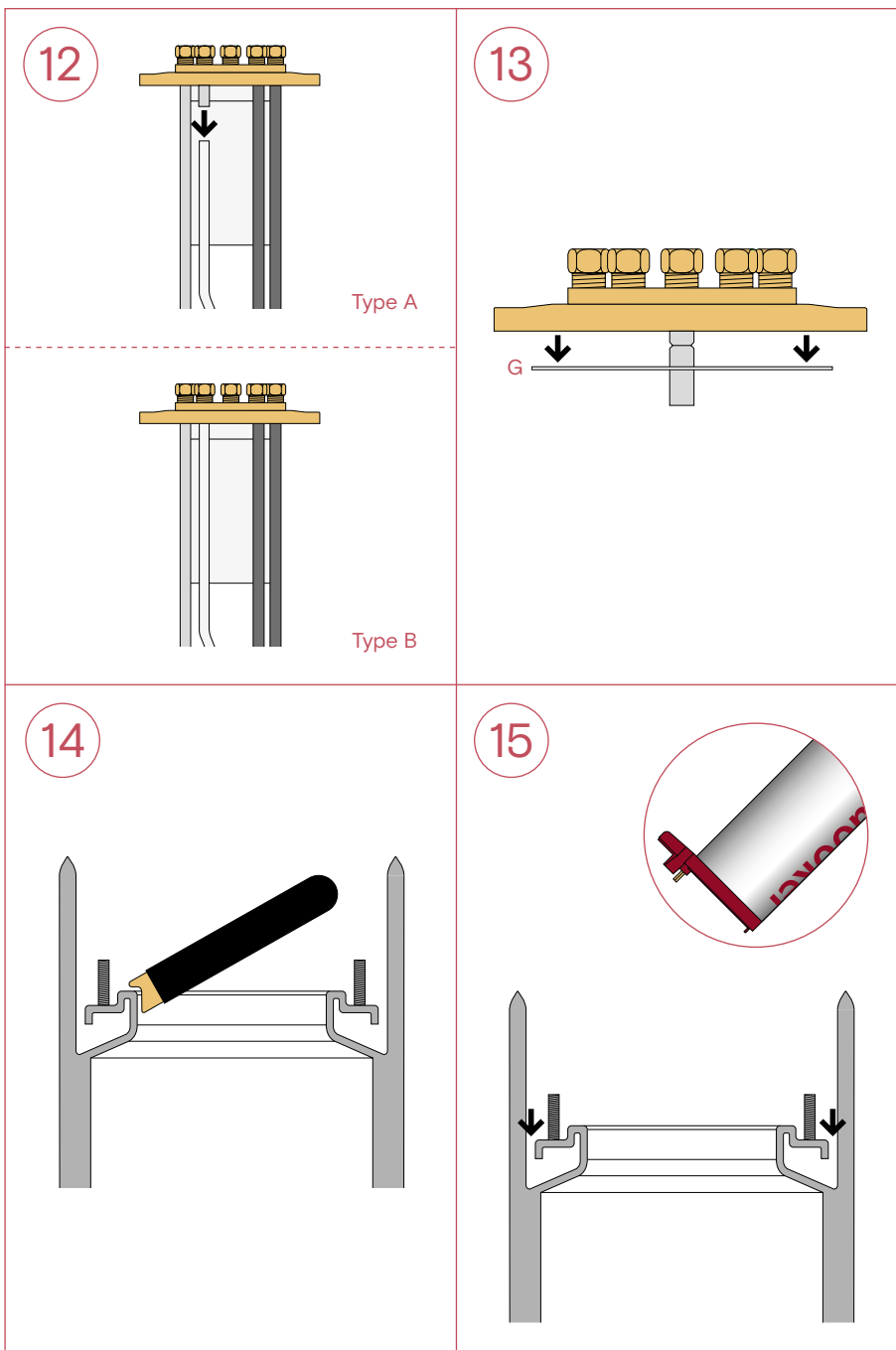

16. To put the tank back together correctly, first place the tank in front of you with the red Quooker logo facing you. Accurately line up the notch of the red plastic rim with the logo on the outside of the tank.
17. Replace the internals and line up the Quooker logo on the internals with the notch of the red ring.
 - Place the eight nuts and tighten them in a diagonal sequence.
18. Now turn the tank a quarter turn clockwise. Replace the insulation. Start with the outer piece.
19. Place the two long hoses between the extended part of the red rim and the brass (distance) nut and push it downward.

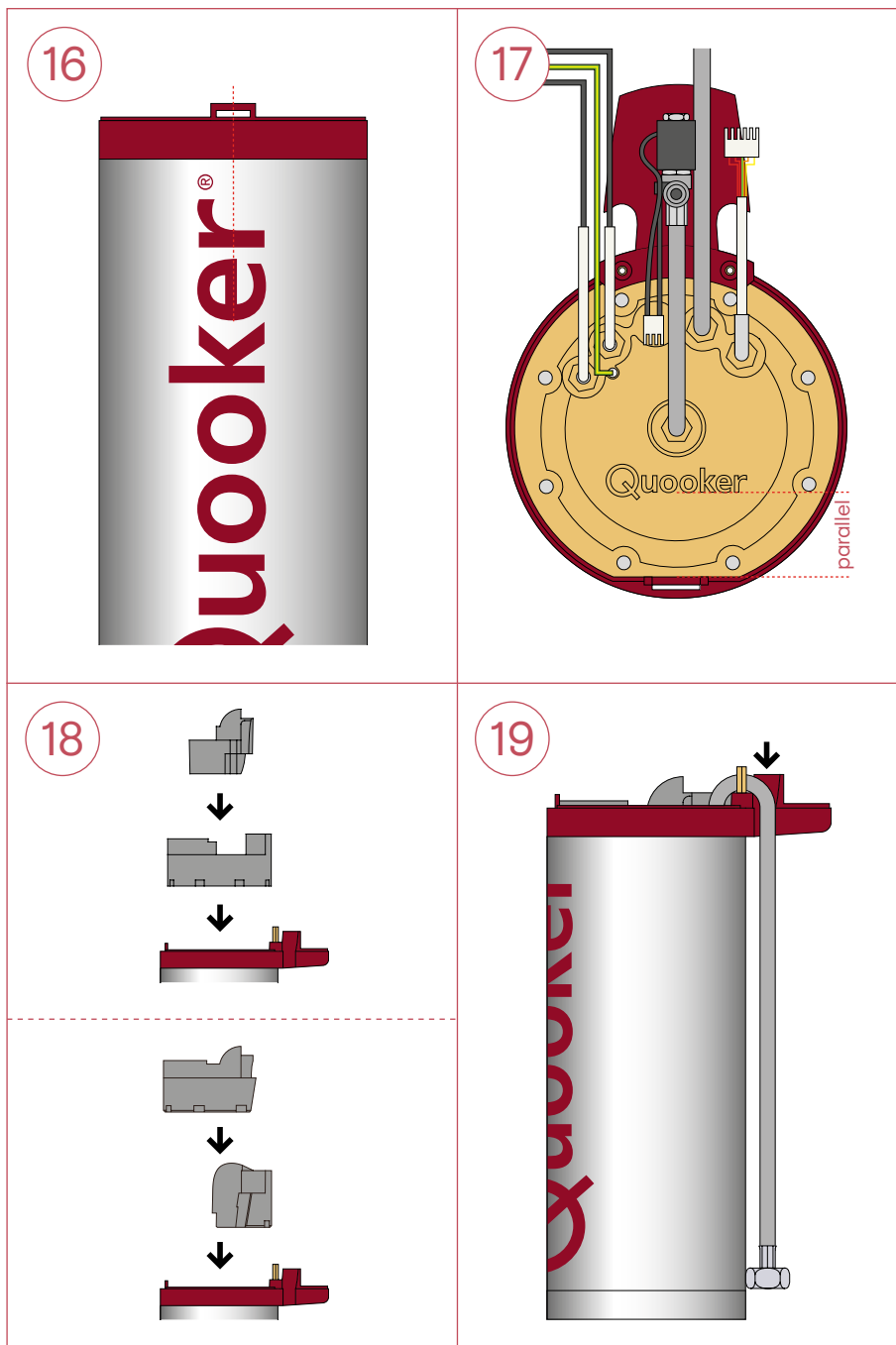

20. Place the hose with the solenoid valve (black cube) over the middle of the insulation.

- Plug the cable connectors into the cover.

21. Push the hose connector partly through the hole in the cover. Place the cover back in the notch. Push it further into place without pinching the cables. Secure the cap screws.

- Connect the hose to the inlet combination using the large red fibre washer. Connect the tap hose to the tank with the small washer. Connect the LED cable. Plug the tank back in. Switch the power on but not the tank yet.

22. Open the boiling-water tap, then the grey stop valve on the inlet combination and flush the tank through for a couple of minutes. At first the drawn off water will be black. This is due to carbon from the activated carbon filter and is perfectly harmless.

- Check for leaks. Switch the tank on with the Q-shaped button.

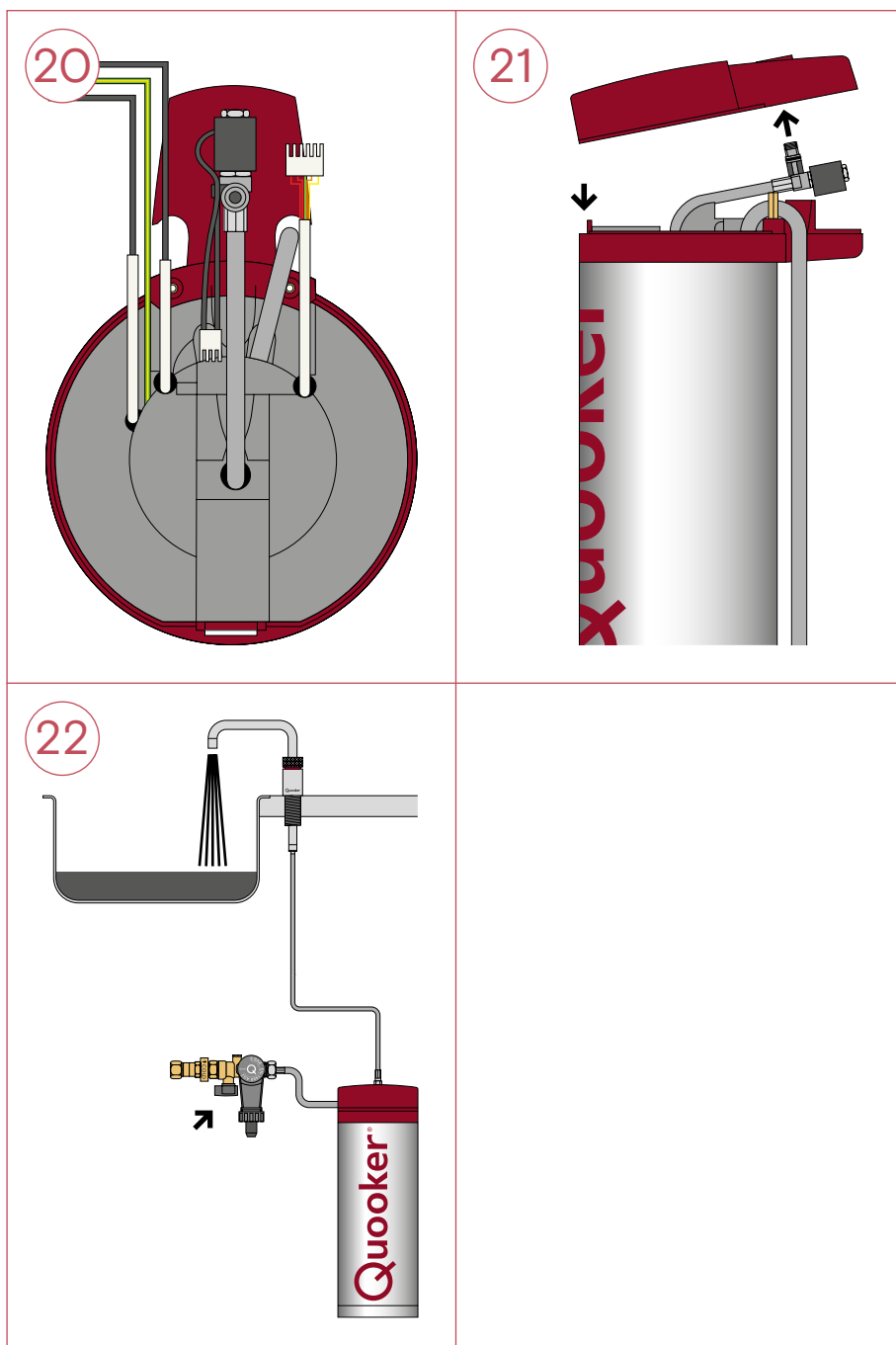

Please note

After switching on the tank, the light should be on both the tap and tank. The tank will be fully heated and ready for use in around 10-20 minutes. After it has heated up, the tap light will go off and the tank light will change to a fading in and out (heartbeat light).

From time to time, unscrew the tap nozzle and descale the aerator in a vinegar-water solution.

For any further questions, do not hesitate to contact our service department on 0207 923 33 55 (option 3 for service) or email us at: service@quooker.co.uk.

Section 2: Replacing the HiTAC® water filter of the regular tank

1. Switch off the tank with the Q-shaped button on top. Do not unplug it or switch off the power yet.
2. Leave it to run until the water is completely cold and the hose between the tap and the tank has cooled down.
3. Close the stop valve (small grey knob) on the inlet combination.
4. Open the boiling-water tap. If it is depressurised, no water will flow out of it.
5. Unplug the tank and disconnect the LED cable from the back of the tank.
6. Disconnect the flexible hose between the tap and the tank by turning the nut anti-clockwise (use spanners 12 and 14).
7. In case of a PRO3-VAQ tank, disconnect the hose from the inlet combination by turning the nut anti-clockwise (use spanner 24). In case of a COMBI tank, disconnect the two hoses from the mixing valve (use spanner 17 and 24). Remove the tank from the kitchen cabinet.

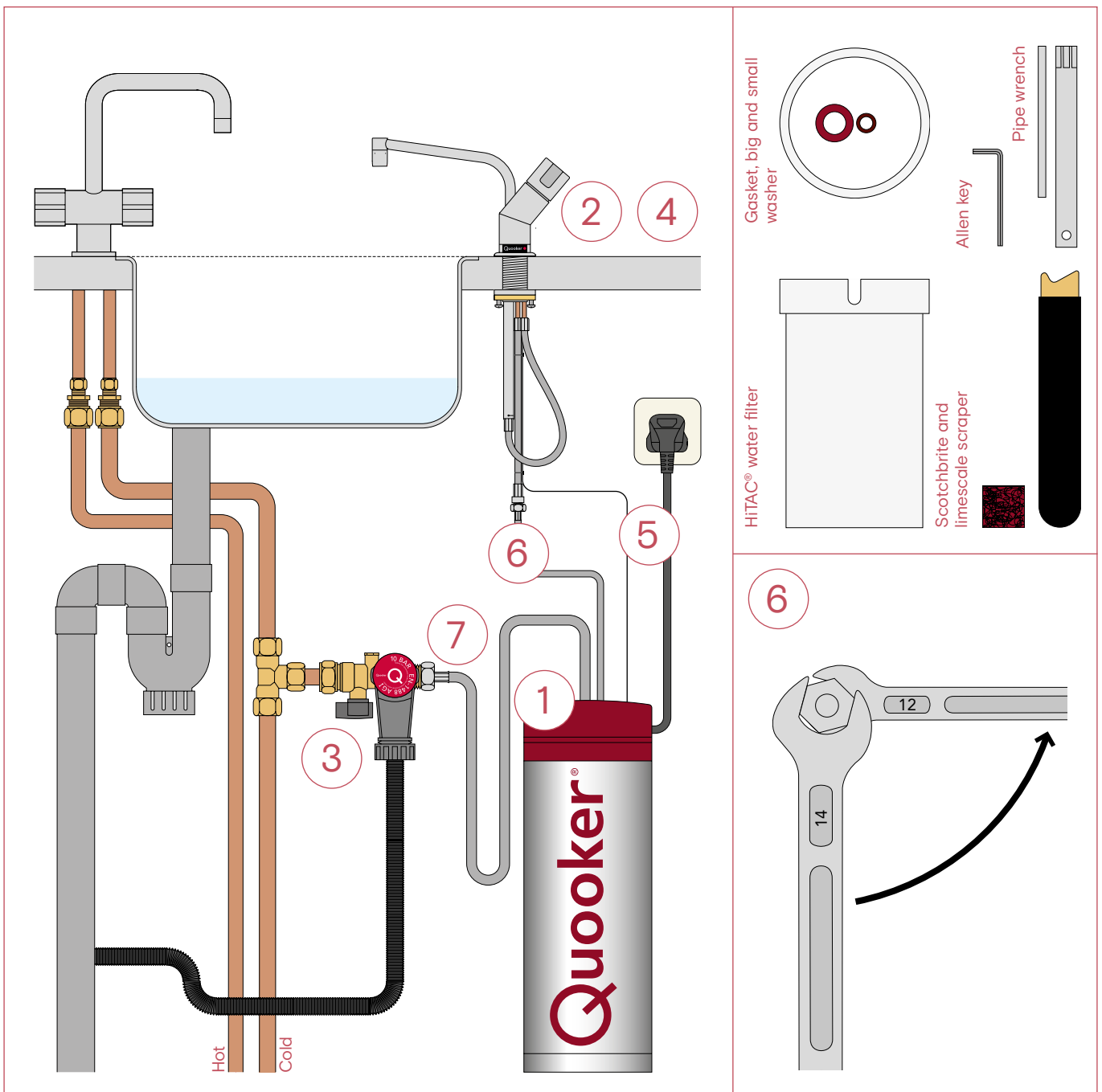

8. Unscrew the cap screws with the supplied allen key, remove the tank cover and disconnect the wire plugs.
9. Remove the insulation.
10. Use the pipe wrench to unscrew the eight nuts and remove the internals.
11. Remove the filter by pulling the metal clips apart.
 - Empty the tank and discard loose scale from it. Use the supplied Scotchbrite and water to lightly remove the bulk of the scale from the tank and internals.

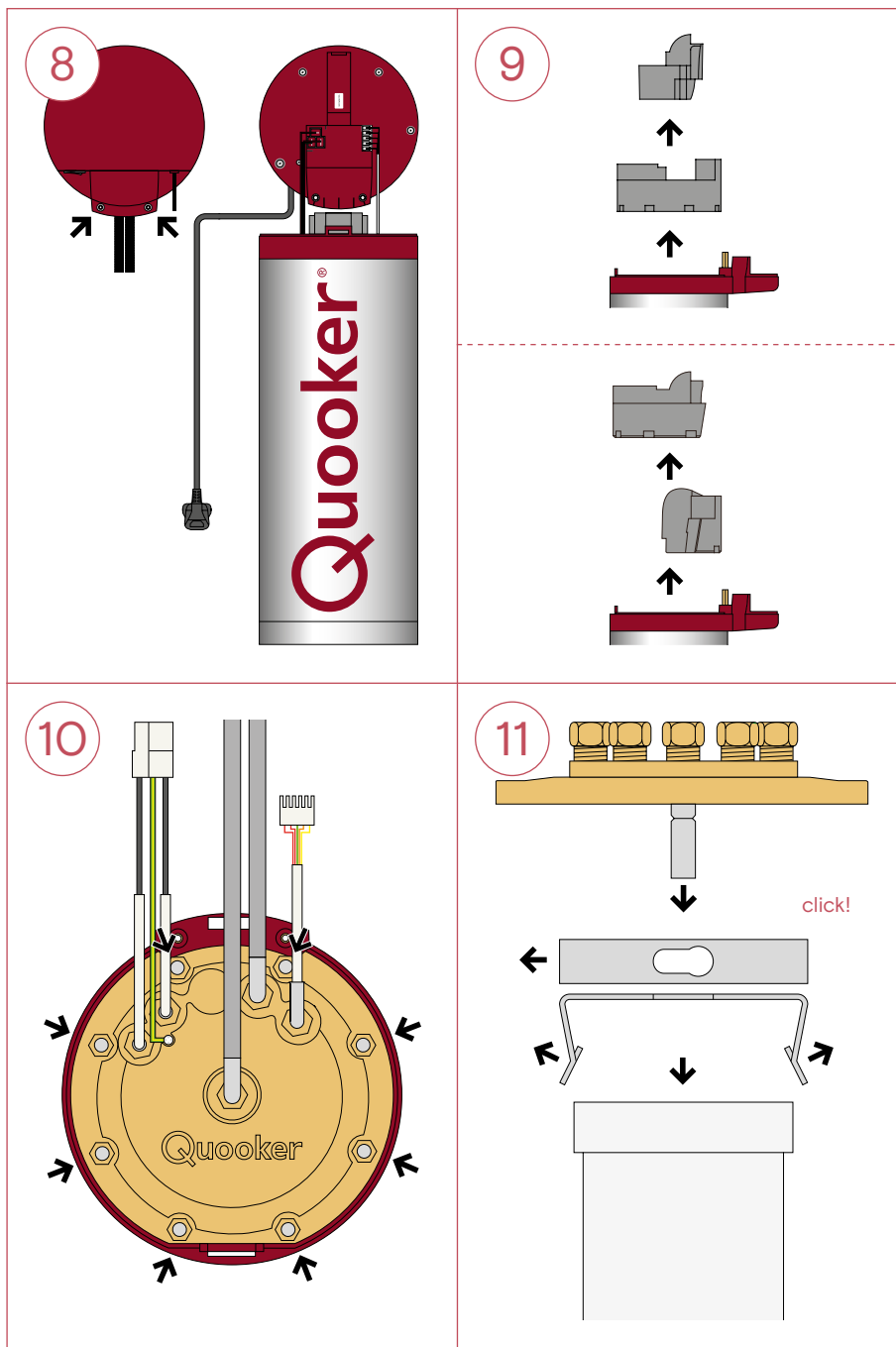

Please note

Do not use any descaling agents or abrasive pads when removing scale from the tank.

12. Type A internals: remove the transparent hose from the metal nozzle at the top. Clean scale from the inside of the nozzle, use the allen key to remove any blockages. Push the hose back in the nozzle all the way.
 - Type B internals: move to step 13.
13. Remove the white gasket (G). Ensure that the surface of the plate is dry and clean and put the new gasket in place.
 - Fit the new HiTAC® filter.
14. Ensure that the rim of the tank is clean by using the scraper and Scotchbrite.
15. Dry the entire rim including the seams and bolts with paper towel, while holding the tank upside down at an angle.

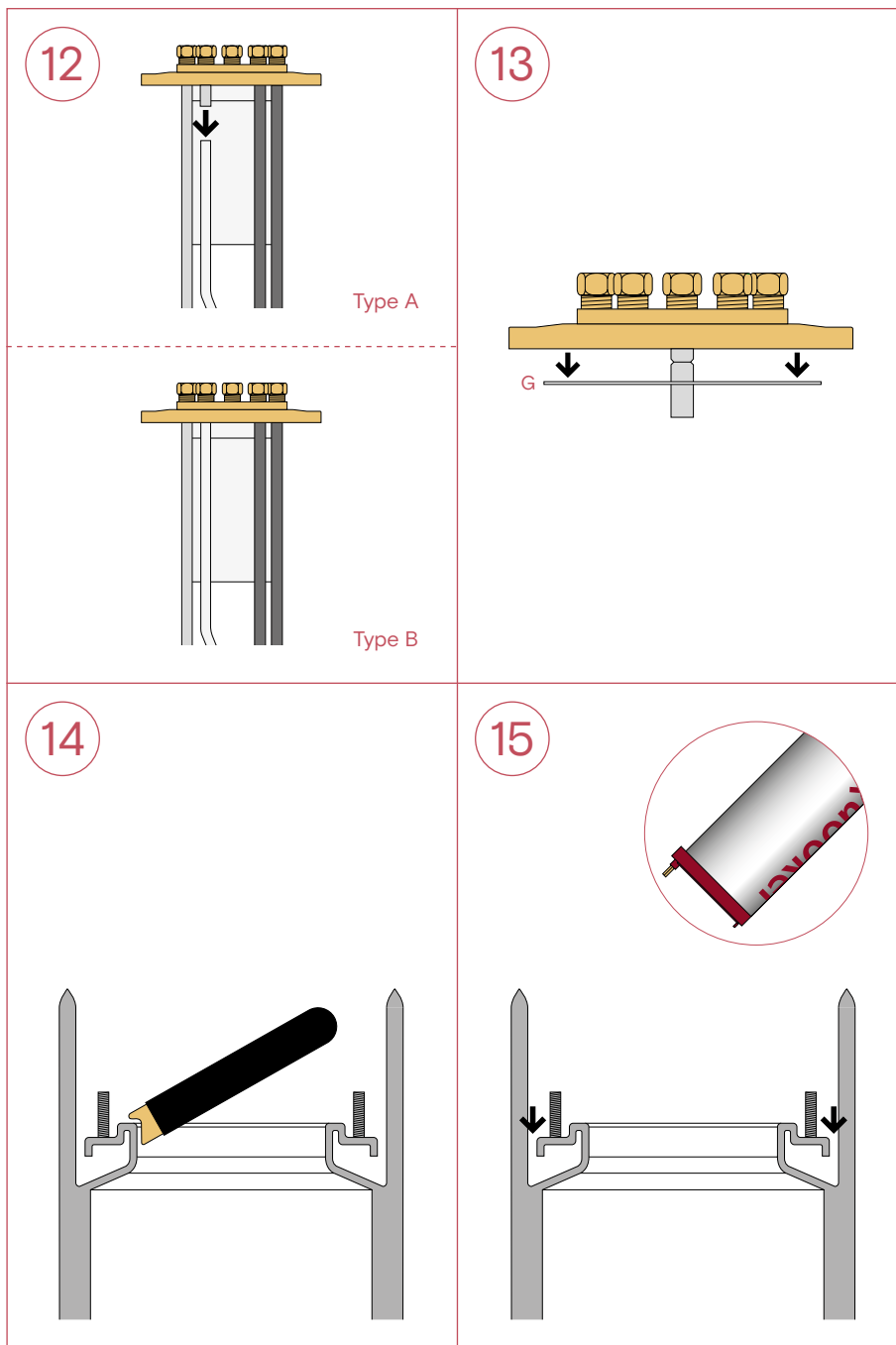

Please note

Step 12 is only necessary if the flow from the tap was reduced. First check if you have a tank with type A or type B internals. Take care not to damage the transparent or braided hose while removing scale blockages.

16. Replace the internals and check the positioning of the Quooker logo relative to the front of the red ring.
 - Place the eight nuts and tighten them in a diagonal sequence.
17. Replace the insulation.
 - Plug the cable connectors into the cover.
 - Replace the tank cover and secure the cap screws. Connect the hoses to the inlet combination and tap using the new fibre washers supplied. Connect the LED cable. Plug the tank back in, but do not switch it on yet.
18. Open the tap, then open the stop valve on the inlet combination and flush the tank through. Switch the tank on with the Q-shaped button.

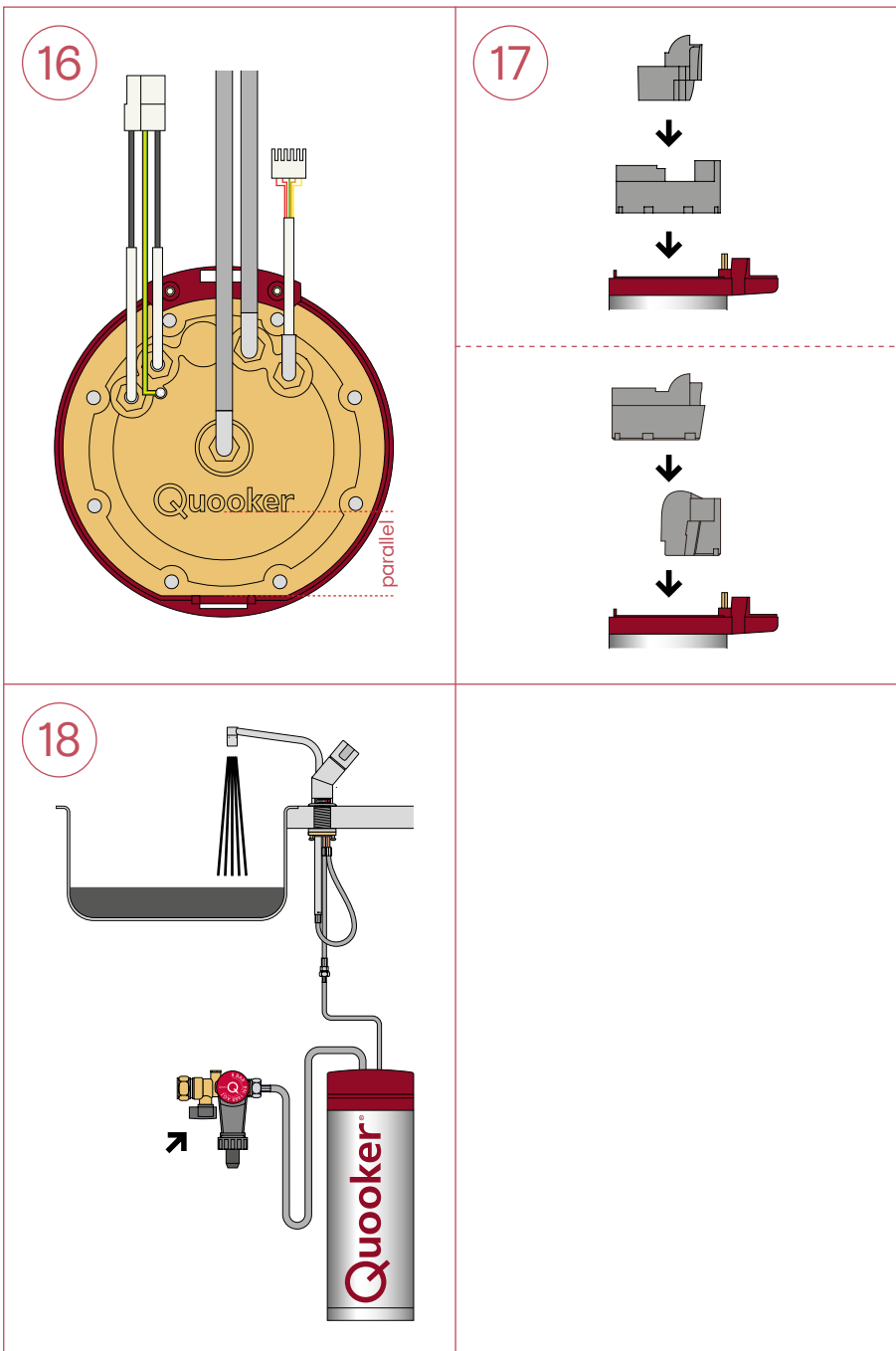

Please note

After switching on the tank, the light should be on both the tap and tank. The tank will be fully heated and ready for use in around 10-20 minutes. After it has heated up, the tap light will go off and the tank light will change to a fading in and out (heartbeat light).

From time to time, unscrew the tap nozzle and descale the aerator in a vinegar-water solution.

For any further questions, do not hesitate to contact our service department on 0207 923 3355 (option 3 for service) or email us at: service@quooker.co.uk.

Quooker®

Quooker UK Ltd.
Beaumont Buildings
Great Ducie Street
Manchester
M3 1PQ (UK)
+44 (0)207 923 3355
info@quooker.co.uk
www.quooker.co.uk